



Accelerator conceptual design of the international fusion materials irradiation facility

M. Sugimoto^{a,*}, R.A. Jameson^b, V. Teplyakov^c, D. Berwald^d, B. Blind^b,
D. Bruhwiler^d, H. Deitinghoff^e, R. Ferdinand^f, M. Kinsho^a, H. Klein^e,
J.-M. Lagniel^f, A. Miyahara^g, M. Olivier^h, M. Peakock^d, E. Piechowiakⁱ,
Y. Pozimski^e, J. Rathke^d, Y. Tanabe^j, K. Volk^e

^a Intense Neutron Source Laboratory, Japan Atomic Energy Research Institute, Tokai-mura, Ibaraki 319-11, Japan

^b Los Alamos National Laboratory, Los Alamos, NM 87545, USA

^c Institute for High Energy Physics, 142284 Protovino, Moscow Region, Russian Federation

^d Northrop Grumman Corp., 1111 Stewart Ave., Bethpage, NY 11714, USA

^e Institut für angewandte Physik der Johann-Wolfgang-Goethe-Universität, D-60054 Frankfurt, Germany

^f CEA Saclay LNS, F-91191 Gif-sur-Yvette, Cedex, France

^g Teikyo University, Hachioji-shi, Tokyo 192-03, Japan

^h CEA DSM, Saclay, F-91191 Gif-sur-Yvette, Cedex, France

ⁱ Northrop Grumman Corp., Baltimore, MD 21203, USA

^j Toshiba Corp., Suehiro-cho, Tsurumi-ku, Yokohama 230, Japan

Abstract

The accelerator system of the International Fusion Materials Irradiation Facility (IFMIF) provides the 250-mA, 40-MeV continuous-wave deuteron beam at one of the two lithium target stations. It consists of two identical linear accelerator modules, each of which independently delivers a 125-mA beam to the common footprint of 20 cm × 5 cm at the target surface. The accelerator module consists of an ion injector, a 175 MHz RFQ and eight DTL tanks, and rf power supply system. The requirements for the accelerator system and the design concept are described. The interface issues and operational considerations to attain the proposed availability are also discussed. © 1998 Published by Elsevier Science B.V. All rights reserved.

1. Introduction

The International Fusion Materials Irradiation Facility (IFMIF) is an accelerator-based intense neutron source to develop the materials for the fusion reactor environment. A conceptual design activity (CDA) of the IFMIF [1] have been carried out for last two years and the final design report was completed in 1996 [2]. During the CDA the accelerator group discussed about the basic problems to establish the baseline parameters, e.g. the accelerator type and the frequency, to achieve the users requirements on the irradiation neutron field [3]. The

derived top-level performance required for the IFMIF accelerator is shown in Table 1. The total output current of 250 mA is provided by two identical 125-mA radio-frequency linear accelerator (rf linac) modules in parallel operation. This reduces the engineering difficulties to develop such high current machine and helps to continue the irradiation tests even though one accelerator module is failed. In the following section, the concept of the linac module and the beam transport system to combine the two beams on the targets is described. The baseline design assumes the use of the conventional, room-temperature, rf linac technology. However, the advanced technologies, such as superconducting linac, are investigated as the alternatives. Since the IFMIF consists of several sub-facilities, the interface issues are important to keep the integrity of the concept. The required

* Corresponding author. Tel.: +81 29 282 6819; fax: 81 29 282 5460; e-mail: sugimoto@ifmif.tokai.jaeri.go.jp.

Table 1
Top-level performance requirements for IFMIF accelerators

Requirement	Specification	Detail/Comment
Particle type	D ⁺	H ₂ ⁺ for testing (avoids activation)
Accelerator type	rf linac	175 MHz, 8 MeV RFQ followed by 8–40 MeV, 175 MHz DTL
Number of accelerators	2	Parallel operation
Output current	250 mA	Potentially upgradeable to 500 mA by adding more accelerator modules
Beam distribution	Rectangular flat top	20 cm horizontal × 5 cm vertical
Output energy	32, 36, or 40 MeV	User selectable
Output energy dispersion	±0.5 MeV FWHM	
Duty factor	cw	Pulsed tune-up and start-up
Availability	≥ 88%	During scheduled operation
Maintainability	Hands on	For accelerator components up to final bend in HEBT with local shielding as required; design not to preclude capability for remote maintenance.
Design lifetime	40 yr	

availability, 88% during the scheduled operation time, is so high that the operation problem is also critical. The operational considerations involving the accelerator safety and the Reliability Availability Maintainability (RAM) are discussed. As a summary, the required development issues are presented.

2. Accelerator concepts

The IFMIF accelerator system consists of two linac modules, each of which can provide a 125 mA and 40 MeV continuous wave (CW) deuteron beam, and the beam transport to merge them into a common footprint with 20 cm width by 5 cm height at the target surface. Each linac module comprises of the subsystems, such as injector, radio-frequency quadrupole (RFQ) linac, drift-tube linac (DTL), and rf power supply. The configuration of these subsystems except the rf power supply is shown in Fig. 1, which is located in the accelerator vault (7.5 m W × 59 m L × 6 m H) at the underground level in

a heavy radiation shield. Fig. 2 represents the cross-sectional view of the accelerator complex at the middle of RFQ. Two accelerator vaults have the different levels, -8.5 and -13.5 m respectively, due to the ±10° beam injection at 14 m upstream from the target. The rf power supply stations stay at the ground level and provide the rf power to each linac cavity using the long rf transport line through the service gallery. The high energy beam transport (HEBT) system starts at the exit of DTL, enters into the beam turning vault and turns to three locations of target stations (two liquid lithium flowing targets and one beam calibration dump). Fig. 3 is the plan view of the layout of the two linac modules and the HEBT. The following subsections describe the performance requirements for the major components and the key technology to realize them.

2.1. Injector

The ion injector consists of the ion source assembly and the low energy beam transport (LEBT) to deliver

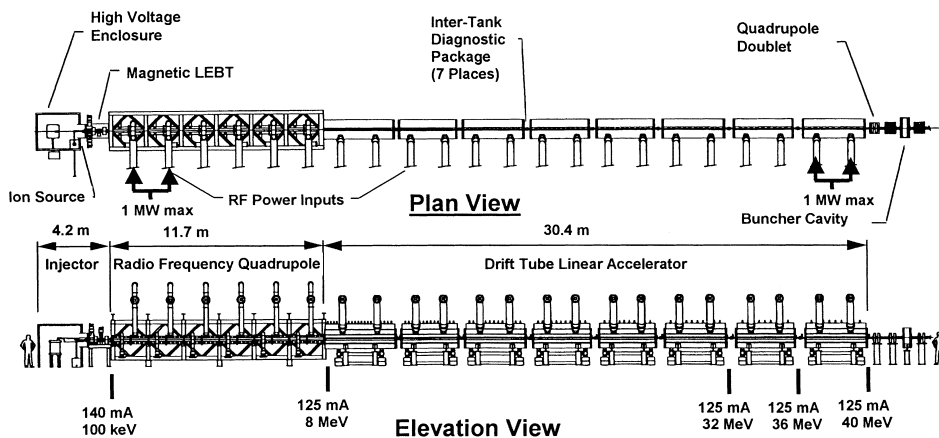

Fig. 1. Layout of a 125-mA, 40-MeV linear accelerator module.

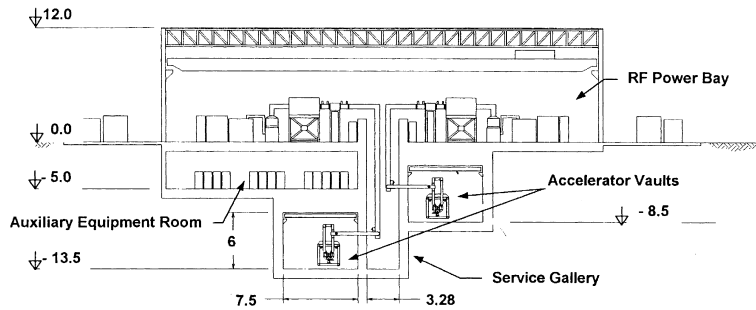

Fig. 2. Accelerator complex section through the RFQ tank (all dimensions in m).

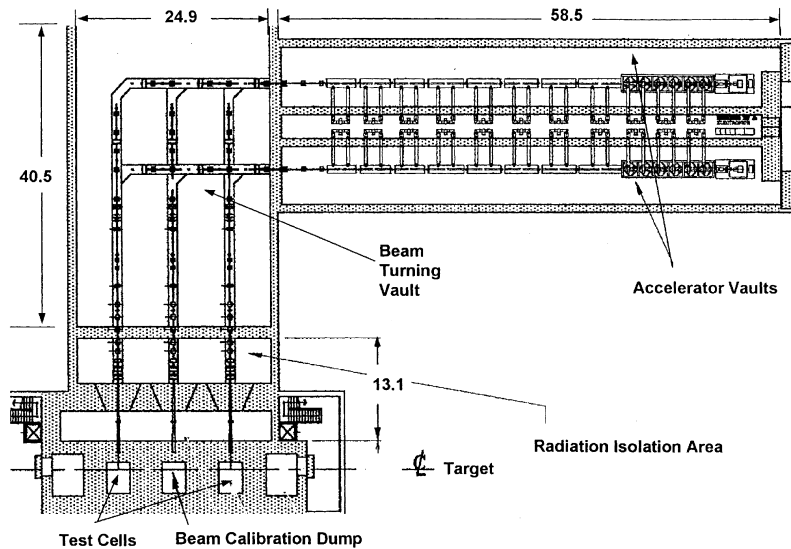

Fig. 3. Plan view of the two accelerators and the beam turning vaults.

the enough quantity and quality of the deuteron beam to the RFQ. The RFQ can accelerate 90% of the injected beam so that the 140 mA beam is required at the entrance of the RFQ. As the transmission through the LEBT is about 90%, the required D^+ current at the ion source is 155 mA. The beam quality is characterized by the transverse emittance and the energy spread. The temporal beam characteristics, such as the current noise fluctuation, the stability of the beam size/position/energy and the source lifetime, are also important to achieve the availability request. The major performance requirements are as follows: (1) source type: volume or ECR. Quick change-out design, (2) output energy: 100 keV, (3) current noise: $\pm 1\%$ at <1 MHz frequency, (4) normalized rms emittance: 0.2π mm mrad, (5) lifetime: >300 h (1000 h goal). It should be noted that H_2^+ beam is used for the test operation and the pulse modulation capability (>1 ms macropulse width at 1–20 Hz repetition) is switched on at tune-up or start-up stage. The LEBT consists of two solenoid lenses, steering dipoles and the

minimal number of the diagnostics. Using this configuration, small beam size and aberrations can be obtained due to the space charge compensation effect. The molecular beam (D_2^+ , D_3^+) from ion source is unfocused by the solenoids and lost at the entrance of the RFQ.

2.2. RFQ and DTL

The RFQ accelerates the 100 keV dc beam from the injector to 8 MeV and makes the bunched beam acceptable by the DTL. The output energy is determined by trading off the focusing capability of quadrupole magnet in the first DTL tank and the length and rf power dissipation of the RFQ. The output energy of DTL is selectable from 32, 36 and 40 MeV. The single frequency of 175 MHz is chosen as the baseline for both linacs to avoid the degradation of the beam quality due to the frequency jump. The output energy of RFQ is selected because it allows a F \bar{O} D \bar{O} magnetic lattice in the DTL which is desirable for halo control and the

consequent minimization of beam loss. A long RFQ structure of 11.7 m is necessary to obtain 8-MeV output energy and the segmented RFQ [4] design is employed. Three longitudinal rf segments are resonantly coupled through irises in intermediate end walls, and each segment consists of three physical segments with ~ 1.3 m length, which can be fabricated by brazing or electroforming technique. A box structure surrounding the cavity supports the RFQ to maintain the straightness and avoid the low frequency vibration. The RFQ has 12 rf drive loops and each of them handles about 250 kw (3 MW total power consumption at full power operation). Activation of the RFQ cavity is a potential concern for maintenance but the highest levels of activation are anticipated to be in the last four to five meters of the cavity, not in the first physical segment. The use of local shielding with a suitable cooling down time is adequate in the case of the replacement of the first segment damaged by erosion.

The DTL design is based upon conventional Alvarez technology with post couplers for field stabilization. Eight tanks have a peak accelerating field of 1.71 MV/m and provide 4 MeV energy gain per tank, which are determined from the maximum available power, 1 MW, per rf station. The first tank has a ramped field gradient that begins at 1.39 MV/m to match the longitudinal focusing out of the RFQ to the new structure. Energy selectivity is achieved by selectively powering the final three DTL tanks with re-tuning of the electromagnetic elements of the beamline in accordance with the operating energy. The drift tubes are mounted in the cavity using a full length, top mounted girder to allow the drift tubes to be installed and aligned prior to installation, and also to be removed and replaced if required. The electromagnetic quadrupoles (EMQs) in the drift tubes will be semi-radiation hard, similar to those used in the LAMPF accelerator.

2.3. RF system

The RF system of the IFMIF accelerator uses a single type of high power amplifier tube in all 12 rf stations as the result of the system-level trade-off studies. However, each amplifier power level should be matched to the specific requirements of each station. At present no tube satisfying the requirements, 1 MW cw at 175 MHz with lifetime >1000 h, is commercially available. Below 200–300 MHz, tetrode is a proven high-power rf power source and the candidates are Eimac 4CM2500KG and Thomson TH628, that have been previously used in other high power rf applications (primarily to provide cw ion cyclotron heating in tokamaks). Since the gain will be relatively low, typically 14 dB, about 50/60 kW of rf drive power is required, ignoring losses and safety factor. Therefore, another tetrode with the capability of at least 100 kW is required

as a driver tube. The quality of the rf delivered to the accelerator cavities is controlled to within $\pm 1^\circ$ in phase and to within $\pm 1\%$ in amplitude, with a low-level rf control system that is based upon the use of in-phase and quadrature control method. The primary power interfaces to the rf stations will be at 13.2 kV, 3 phases, 50/60 Hz and will have a separate power supply at each rf station. A solid-state preamplifier is being considered to maximize the reliability of the rf chain. The rf station consists of the power amplifier chain described above, the rf source and reference distribution, internal cooling loops within each rf station that interface to the IFMIF site cooling system, and status, monitor, and control interfaces that maintain communication with the master control system via data bus interconnections.

2.4. HEBT

The HEBT transports the 125 mA beam from the exit of the DTL to either one of two lithium targets or the beam calibration dump [5]. The design keeps manipulations of the beam by all beamlines as similar as possible to ensure similar beam dynamics for each channel and minimize the different types of magnetic elements needed. The generously spaced doublet lattice can minimize the number of required quadrupoles. Each HEBT contains a 90° achromatic bend and a final 10° vertical bend placed at 14 m upstream of the target for protecting most of the HEBT components from backstreaming neutrons. The distance between three targets is 7.2 m for ample neutron shields, so the periodic lattice upstream of the 90° bend is designed with a 2.4-m cell length and with a buncher cavity in every third cell. The accelerators are 11 m apart, so the periodic lattice downstream of the 90° bend is designed with a 2.75-m cell length and with a buncher cavity in every other cell. Immediately downstream of each accelerator is a six-quadrupole, three-cavity matching section to match in all six dimensions. The nonlinear beam expander has an octupole component for beam redistribution and a duodecapole component for halo containment. Energy dispersing cavities are placed in a 1-m section of beamline after the 10° dipole to provide the desired FWHM dispersion of ± 0.5 MeV. A beam calibration dump is used to validate performance and to make final beam adjustments prior to injecting the beam into the lithium target and it can accept a 2% duty factor, 125-mA beam.

2.5. Alternatives

The superconducting rf linac (SCL) has technical and operational advantages for electron and heavy-ion beam applications. It can be considered the SCL as the 8–40 MeV portion of the IFMIF accelerator because it saves rf power due to the absence of wall losses [6]. Since each cavity in SCL is powered by independent rf power

supply, the use of solid state amplifier can be feasible with further development and cost reduction. The SCL offers the possibility to operate with failed accelerating cavities, which increases the accelerator availability significantly.

The high energy part, 3–8 MeV, of the IFMIF RFQ can be replaced by the Space-Periodic RFQ (SPRFQ) structure, which uses H-type resonators inside an outer vessel [7]. Capacitance added in a controlled manner through the SPRFQ allows a large increase in the vane voltage, and this results in considerably shorter length and less total rf power loss.

3. Interface and operational considerations

The physical interface between the accelerator and the target/test cell systems is at a beamline valve in the radiation isolation area shown in Fig. 3. The tolerance of beam-on-target centroid positioning is ± 1 mm and the desired characteristics of spatial and energy beam profile is defined. The beam temporal characteristics are also important interface issues. During the accelerator turn-on, the beam current is ramped up gradually. The control of the average beam current is carried out by using pulse modulation capability with >1 ms width and 125-mA peak current. This method may produce a beam loss at the transient region of each pulse, so the integrated beam loss should be controlled by quick adjustment of the accelerator components.

The interface issues with the conventional facilities are equivalent to the requirements for the support systems, such as electrical power supply, cooling water, and central control system. The safety issue especially for radiation protection plan is important to keep the system availability. The preliminary analysis indicates no severe hazard is identified if the beam interlock works properly. RAM analysis assigns the availability budget for each sub component based on the experiences of the industry and large accelerator facilities. As a result, more than 95% availability is requested to each subsystem, injector, linac, rf system and HEBT, respectively.

4. Concluding remarks

The concept of the IFMIF accelerator system is based on the existing technology used in the lower beam intensity applications. However the suppression of the

beam loss and the highest stability of each component in the operation are critical for the IFMIF intensity level. So it is a key issue to confirm the engineering and operational properties through the prototype development, especially for the injector and the CW-RFQ. In the past, several high-current CW-RFQs [8] are developed, e.g. a 50-mA, 2-MeV H_2^+ FMIT-RFQ at Los Alamos and a 80-mA, 0.6-MeV H^+ RFQ1 at Chalk River, however, no CW-RFQ for deuteron has been operated. The development schedule is planned and the following items are identified: (1) System issues: beam loss specification, mechanism and control of beam loss, lower frequency choice, rf system control design, beam instrumentation. (2) Injector: engineering validation of the prototype. (3) RFQ/DTL/SCL/HEBT: beam loss model, beam matching. (4) RF power: engineering validation of high power tube and rf window, development of solid state high power amplifier.

Acknowledgements

The technical contributions provided by all the participant members of the IFMIF-CDA are gratefully acknowledged. The service staffs who co-ordinated the technical meetings during the CDA are also appreciated.

References

- [1] T. Kondo, T.E. Shannon, K. Ehrlich, *J. Nucl. Mater.* 233–237 (1996) 82.
- [2] IFMIF CDA Team, in: M. Martone (Ed.), IFMIF International Fusion Materials Irradiation Facility Conceptual Design Activity Final Report, ENEA RT/ERG/FUS/96/11, December 1996.
- [3] J.E. Leis et al. (Eds.), Report on International Fusion Irradiation Facility, vol. 1, Evaluation Panel Report, vol. 2, Technical Presentations, Workshop San Diego, USA, 14–17 February 1989.
- [4] L.M. Young, in: Proceedings of 1994 International Linac Conference, Tsukuba, Japan, 21–26 August 1994, p. 178.
- [5] B. Blind, LA-UR-96-3621, October 1996.
- [6] Y. Tanabe, N. Kakutani, T. Ota, A. Yamaguchi, O. Takeda, Y. Wachi, C. Yamazaki, Y. Morii, *Fus. Eng. Des.* 36 (1997) 179.
- [7] V.A. Teplyakov, private communication.
- [8] G.E. McMichael, in: Proceedings of the 1991 IEEE Particle Accelerator Conference, San Francisco, California, 6–9 May 1991, vol. 4, p. 2093.